

# Crosley

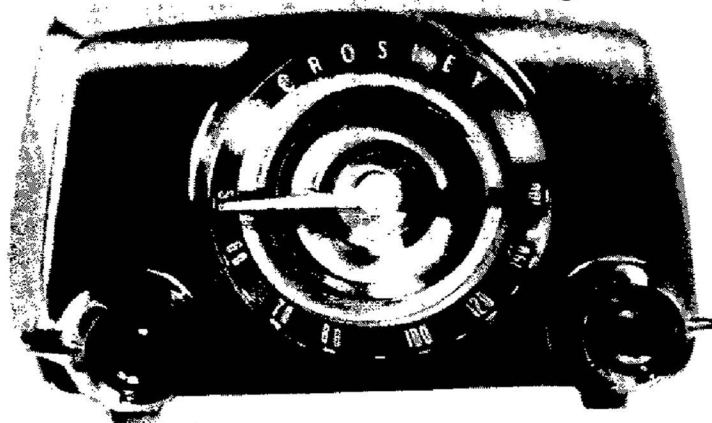

Model No.	Color
11-100U	White
11-101U	Blue
11-102U	Green
11-103U	Red
11-104U	Ebony
11-105U	Chartreuse / Celery

## DESCRIPTION

**TYPE:** Five-tube, single band, Superheterodyne.  
**FREQUENCY RANGE:** 540 to 1600 kc.  
**INTERMEDIATE FREQUENCY:** 455 kc.  
**POWER SUPPLY:** a.c.-d.c.  
**VOLTAGE RATING:** 105-125 volts.  
**POWER CONSUMPTION:** 30 watts.  
**POWER OUTPUT:** 1.5 watts maximum.

## TUBE COMPLEMENT

Type	Function
12BE6	Converter
12BA6	I. F. Amplifier
12AV6	Detector, AVC, 1st A.F. Amplifier
50C5	A.F. Power Output
35W4	Rectifier

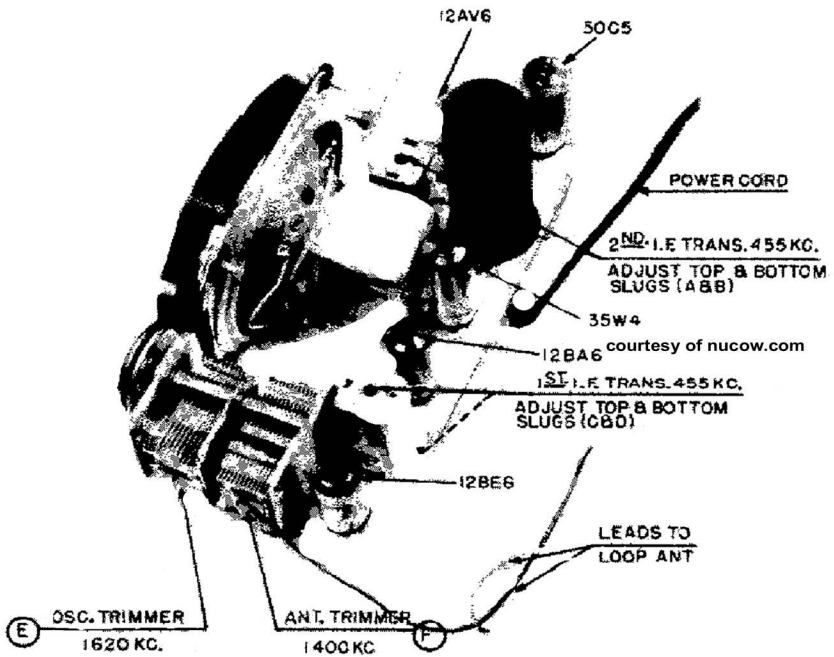

**CHASSIS, TOP VIEW**

# Crosley

- models  
 11-100U  
 11-101U  
 11-102U  
 11-103U  
 11-104U  
 11-105U

## Chassis 301

# SCHEMATIC DIAGRAM

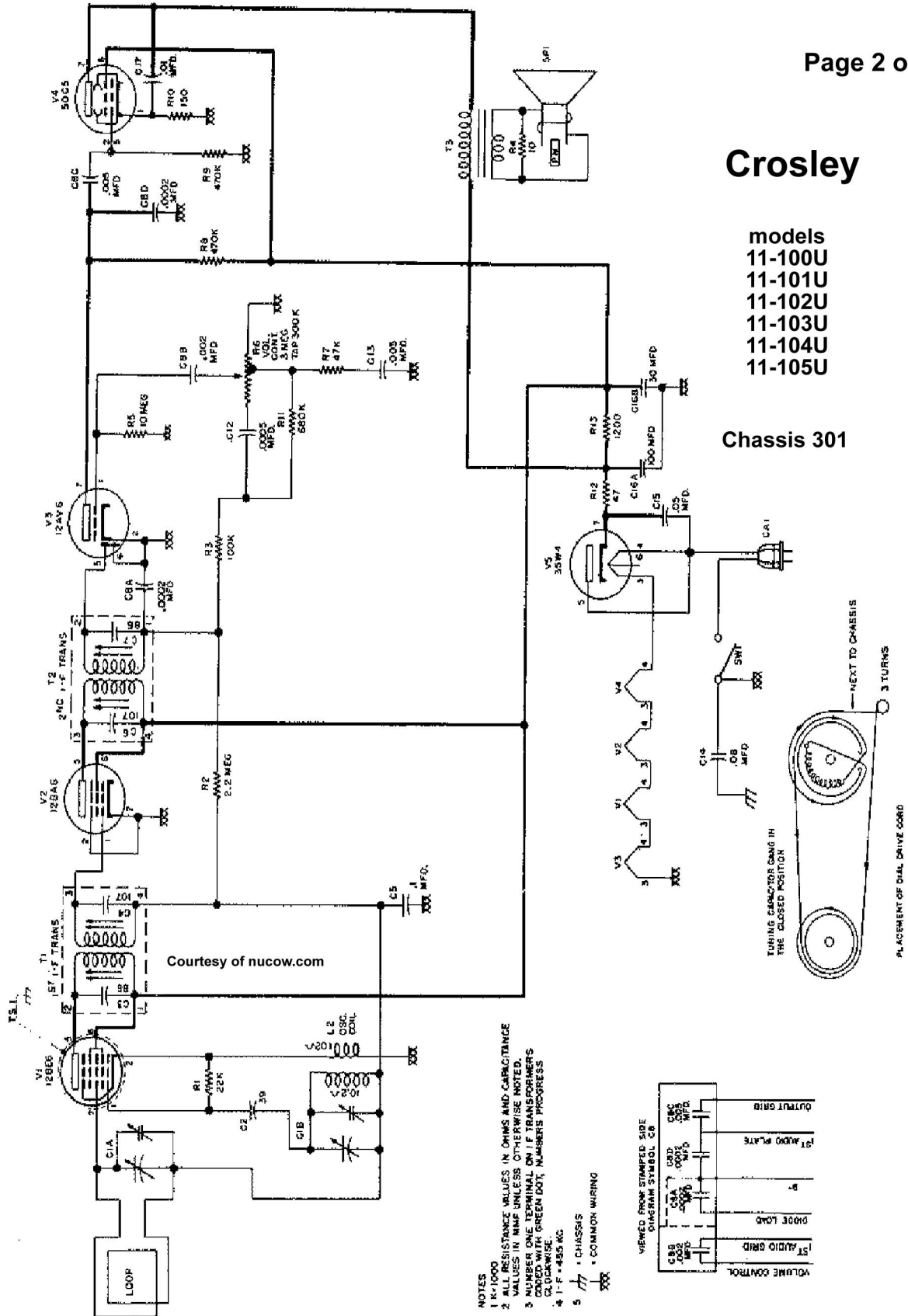

TUNING CAPACITOR GANG IN THE CLOSED POSITION

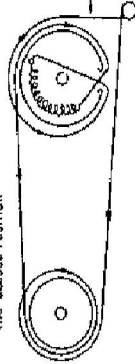

PLACEMENT OF DIAL DRIVE CORD

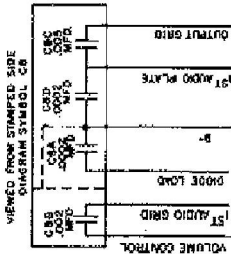

- NOTES  
 1 R-1000  
 2 ALL RESISTANCE VALUES IN OHMS AND CAPACITANCE VALUES IN PPF UNLESS OTHERWISE NOTED.  
 3 VALUES IN MFD UNLESS OTHERWISE NOTED.  
 4 1-F = 485 KC.  
 5 \* CHASSIS  
 \* COMMON WIRING

Courtesy of nucow.com

# Crosley

models

11-100U  
11-101U  
11-102U  
11-103U  
11-104U  
11-105U

Page 3 of 6

## Chassis 301 and 303

When using direct current it may be necessary to reverse the position of the power plug in the electric outlet for correct polarity.

Reversing the position of the power plug when alternating current is used may reduce hum.

*Under no circumstances should a ground be connected to this receiver.*

### ALIGNMENT PROCEDURE

1. Connect an output meter across the speaker voice coil.
2. The r.f. signal input from the signal generator should be connected as indicated in the alignment chart. Connect the signal generator ground through a 0.1 mfd. condenser to B - (pin 2 on 12BA6 tube socket).
3. Turn the volume control on full and adjust the signal generator output to produce approximately midscale deflection of the output meter, but maintain signal generator output as low as possible to prevent AVC action in the receiver.

### ALIGNMENT CHART

Alignment adjustment locations are shown on page 1, "CHASSIS, TOP VIEW."

Alignment Sequence	Signal Generator Output			courtesy of nucow.com Position of Dial pointer	Adjust for Maximum Output
	Frequency in KC	In Series with	To		
1	455	200 mmf.	High Side of Loop	1620	A, B, C & D (See Note 1.)
2	1620	Radiated to Loop		1620	E (See Note 2.)
3	1400	Radiated to Loop		Tune to Signal	F (See Note 2.)

### ALIGNMENT NOTES

1. Repeat adjustments (A, B, C & D) in sequence, until maximum output is obtained.
2. Place signal generator output lead near the loop antenna. The loop antenna must be positioned with respect to the chassis to simulate its position when chassis and loop are fastened in cabinet.

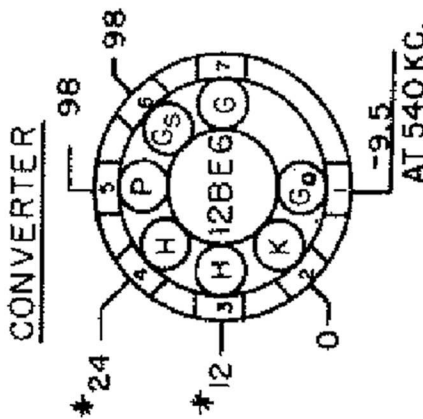
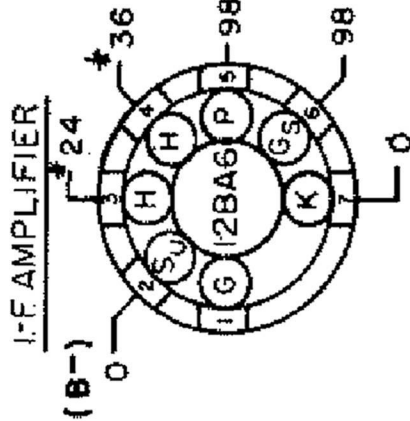
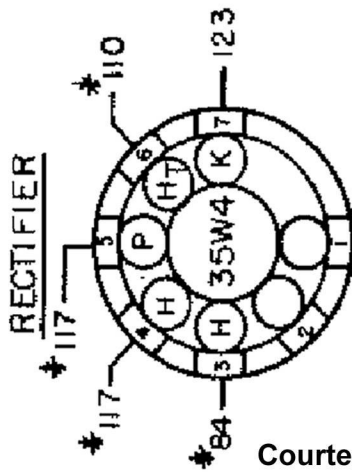
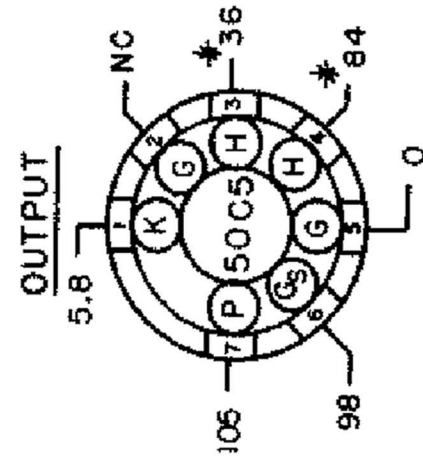

DET - AVC - 12AV6 AUDIO AMPL.

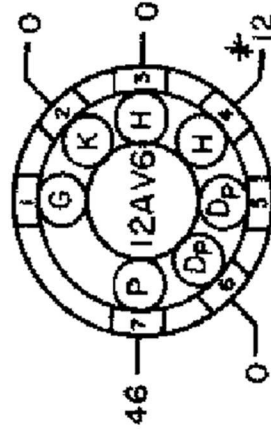

Courtesy of nucow.com

**Crosley**  
models

- 11-100U
- 11-101U
- 11-102U
- 11-103U
- 11-104U
- 11-105U

Chasis 301

**NOTES:**

1. BOTTOM VIEW OF TUBE SOCKETS.
2. MEASURE VOLTAGE WITH AN ELECTRONIC VOLTMETER FROM SOCKET LUG TO B - PIN 2 ON THE 12BA6.
3. LINE VOLTAGE 117 V. 60 Hz.
4. NC. = NO CONNECTION.
5. \* = A.C. VOLTAGE
6. SOCKET VOLTAGE TOLERANCE  $\pm 10\%$ .

**SOCKET VOLTAGE CHART**

**Crosley 11-100U, 11-101U, 11-102U,  
11-103U, 11-104U, 11-105U, Ch. 330**

Chassis 330 is similar to Chassis 301, which is also used with the above models, except that the 330 uses a 12SQ7GT (V3) in the detector—avc 1st a-f amplifier stage, whereas the 301 uses a 12AV6. The 12SQ7GT is connected in the following way: pin 1 goes to the shield; pin 2 goes to the junction of R5 and C8B; pin 3 goes to the junction of ground, pin 4, and C8A; pin 5 goes to tap 2 of the 2nd i-f transformer T2, pin 6 goes to the junction of R8, C8C, and C8D; pin 7 goes to pin 3 of V1, and pin 8 is grounded. The voltage readings are as follows: pins 1, 3, 4, and 8 are 0 volts; pin 2 is —0.8 volt; pin 5 is —0.6 volt; pin 6 is 52 volts; pin 7 is 12 volts a.c.

The following part should be added to the parts list: TS2, Part No. W-46447-1, Shield, tube (V3). Courtesy of nucow.com

The following procedure should be used when installing an idler spring (part no. 151085) on the drive shaft:

1. Remove cotter from end of shaft under chassis.
2. Pull drive shaft straight out from chassis being careful to keep drive cord on shaft and pulley.
3. Remove spring washer from shaft.
4. Place idler spring on shaft and then hook one end of the spring under the chassis. The other end of the spring hooks around the portion of drive cord that is between the drive shaft and the tuning capacitor pulley.
5. Place spring washer on the drive shaft, insert drive shaft in chassis, and insert cotter on end of shaft.

Symbol No.	Part No.	Description	Symbol No.	Part No.	Description
C1A	B-148350	Capacitor, Variable } Two Section	L2	AW-148259	Coil, Oscillator
C1B		Capacitor, Variable }	SP1	AD-148400	Speaker
C2	C-137727-109	Capacitor, 39 mmf., 10% 200v., ceramic	SW1	Part of R6	Switch, Power
C3	Part of T1	Capacitor, 86 mmf.	TS1	W-147784	Shield, Tube (V1)
C4	Part of T1	Capacitor, 107 mmf.	T1	C-139919-5	Transformer, 1st I.F.
C5	39001-19	Capacitor, .1 mfd., 600 v., paper	T2	C-139919-5	Transformer, 2nd I.F.
C6	Part of T2	Capacitor, 107 mmf.	T3	138131-1	Transformer, Output
C7	Part of T2	Capacitor, 86 mmf.		AB-148406-1	Baffle & Grille Cloth Assy.
C8A	C-144675-1	Capacitor, .0002 mfd., 500 v. } Courtesy of nucow.com		AB-148465-1	Cabinet (11-100U)
C8B		Capacitor, .002 mfd., 500 v. } Four Sec-		AB-148465-2	Cabinet (11-101U)
C8C		Capacitor, .005 mfd., 500 v. } tion disc		AB-148465-3	Cabinet (11-102U)
C8D		Capacitor, .0002 mfd., 500 v. } ceramic		AB-148465-4	Cabinet (11-103U)
C12	39001-5	Capacitor, .0005 mfd., 600 v., paper		R-148273-3	Cabinet (11-104U)
C13	39001-11	Capacitor, .005 mfd., 600 v., paper		AB-148465-6	Cabinet (11-105U)
C14	39001-85	Capacitor, .08 mfd., 600 v., paper		W-148434	Clip, I.F. Transformer Mtg.
C15	39001-17	Capacitor, .05 mfd., 600 v., paper		W-131154-1	Cotter (External), Tuning Shaft
C16A	B-148357	Capacitor, 100 mfd., 150 v. } Two Section		B-148364	Gasket, Speaker
C16B		Capacitor, 30 mfd., 150 v. } Electrolytic		W-148390	Grommet (3 used), chassis
C17	39001-13	Capacitor, .01 mfd., 600 v., paper		B-148318-1	Knob (11-100U)
R1	39373-60	Resistor, 22,000 ohm, 1/2 w.		B-148318-2	Knob (11-101U)
R2	39373-97	Resistor, 2.2 megohm, 1/2 w.		B-148318-3	Knob (11-102U)
R3	39373-74	Resistor, 100,000 ohm, 1/2 w.		B-148318-4	Knob (11-103U)
R4	39373-1	Resistor, 10 ohm, 1/2 w.		B-147318-5	Knob (11-104U)
R5	39373-107	Resistor, 10 megohm, 1/2 w.		B-148318-6	Knob (11-105U)
R6	B-148327	Control, Volume (3 megohm, Tap 300,000 ohm)		B-94704-7	Nut (Push On), Grille Cloth Mtg.
R7	39373-67	Resistor, 47,000 ohm, 1/2 w.		B-148320	Pointer, Dial
R8	39373-37	Resistor, 470,000 ohm, 1/2 w.		39176-59	Screw, Chassis Mtg.
R9	39373-37	Resistor, 470,000 ohm, 1/2 w.		W-148379	Shaft, Tuning
R10	39373-16	Resistor, 150 ohm, 1/2 w.		AW-148806	Shaft & Pulley Assy., Pointer
R11	39373-90	Resistor, 680,000 ohm, 1/2 w.		39462-2	Socket, Tube
R12	39374-97	Resistor, 47 ohm, 10%, 1 w.		W-148469	Spring (Retainer), Pointer Pulley
R13	39374-114	Resistor, 1200 ohm, 10%, 1 w.		W-51752	Spring, Drive Cord
CA1	CA142769-1	Cable & Plug Assy., Power		AB-148362	Support & Bushing Assy., Pointer Pulley
L1	C-148399	Loop & Back Assy.		W-134916	Washer (Spring), Tuning Shaft

Slipping of dial drive cords on these models can be corrected by replacing the drive cord with a cord long enough to permit it to be wrapped around the drive shaft four turns instead of three turns.

If necessary, place a 1/16" thick #6 flat washer on each screw that mounts the tuning capacitor. The washer should be placed between the rubber grommet eyelet and the capacitor frame. When the mounting screws are drawn tight, the eyelet will then flatten enough to reduce the flexibility of the grommet. This will hold the capacitor rigid and prevent the cord from becoming loose when the drive shaft is rotated.

In addition to the recommendations in the original service instructions it is sometimes necessary to replace the drive shaft with new shaft (part Number 148379). This new shaft does not have a groove for the drive cord.

Also on some sets of models like 11-100U to 11-109U, R2 is a 3.3 megohm, 10%, 1/2 watt resistor instead of a 2.2 megohm resistor; and because of this C5 is an .05 mfd., 600 volt paper capacitor (Part No. 39001-17).